



## ALUMINUM BATTERY BOX INSTALLATION INSTRUCTIONS

### 048100 Series

**WHEN SELECTING MOUNTING LOCATION AND DRILLING MOUNTING HOLES, SPECIAL CARE SHOULD BE TAKEN TO AVOID DRILLING INTO VEHICLE'S FUEL TANK, SPARE TIRE, BRAKE LINES, OR ANY OTHER CRITICAL COMPONENTS.**

1. Determine Battery Box location in vehicle and drill two (2) 3/8 inch mounting holes. To comply with NHRA rule 8:1, battery must be isolated from the passenger compartment and mounted securely to the vehicle's frame.
2. Secure bottom tray in position with the threaded rod, hex nuts, and washers.
3. Install two (2) rubber grommets and vent tube adapter with its' flat washer and locking nut into box body.
4. Position battery in bottom tray. (Some installations will be easier if the battery terminals are situated on the far side of the box away from the notches in the box, thus allowing some flex in the cables to make connections easier).
5. Secure battery with the hold-down bracket, hex nuts, and washers. NOTE: Some batteries may have close spacing between the terminal posts, and some modification of the hold-down bracket may be necessary to fit those batteries.
6. Fit the box body over the battery and into the bottom tray.
7. **NOTE: Connect the RED positive (+) cable first to the Pos (+) terminal of the battery (if negative ground vehicle).** If the vehicle has a Positive ground, then connect the red cable first to the Neg (-) terminal of the battery. To easily pass the cable through the grommets, use liquid dish soap as a lubricant. The red cable terminates at the same location as the cable being replaced. This is typically on the starter solenoid or remote bump starter solenoid (assuming negative ground system). If the cable passes through the firewall or some other barrier where it could rub against bare metal, use the supplied rubber grommet in a 3/4 inch hole to protect the cable insulation.
8. Once the final cable routing is determined, cut the cable to length. To attach the battery cable eyelet terminal, strip one inch of insulation, and slide the cable fully into the threaded hex portion of the eyelet terminal. Finally, thread the hex nut portion into the main body of the eyelet terminal and tighten fully.
9. **Connect the black battery cable to the negative (-) terminal of the battery (if the vehicle has a Negative ground).** For a Positive ground vehicle, connect the black cable to the Pos (+) battery terminal. This ground cable terminates to a solid grounding point such as: the chassis, engine block, the frame or some other similar common point. Be sure any paint or finish is removed from the terminal point for a good electrical connection.
10. Fit the top cover on the box body making sure the rubber grommets are aligned.
11. Secure the top cover on the box with flat washers and wing nuts, then attach the vent tube.

- 1ea 805 Box
  - 2ea 614 nut, 3/8-16 forged wing z/p
  - 1ea 615-2 washer, flat 1/2 ID
  - 6ea 617-5 3/8-16 hex nut z/p
  - 8ea 617-6 3/8 std flat washer
  - 1ea 617-7 7/16-20 nylock hex nut
  - 1ea 617-8 90 deg elbow barbed fitting
  - 3ea 672 blk rubber grommet .450 ID
  - 1ea 808A battery hold down
  - 2ea 819 3/8-16 x 16" threaded rod
  - 6ea 875-9 1/2" cable clamp
  - 1ea 372 clear PVC vinyl tubing
- (Battery Cables are specific to kit part number ordered)

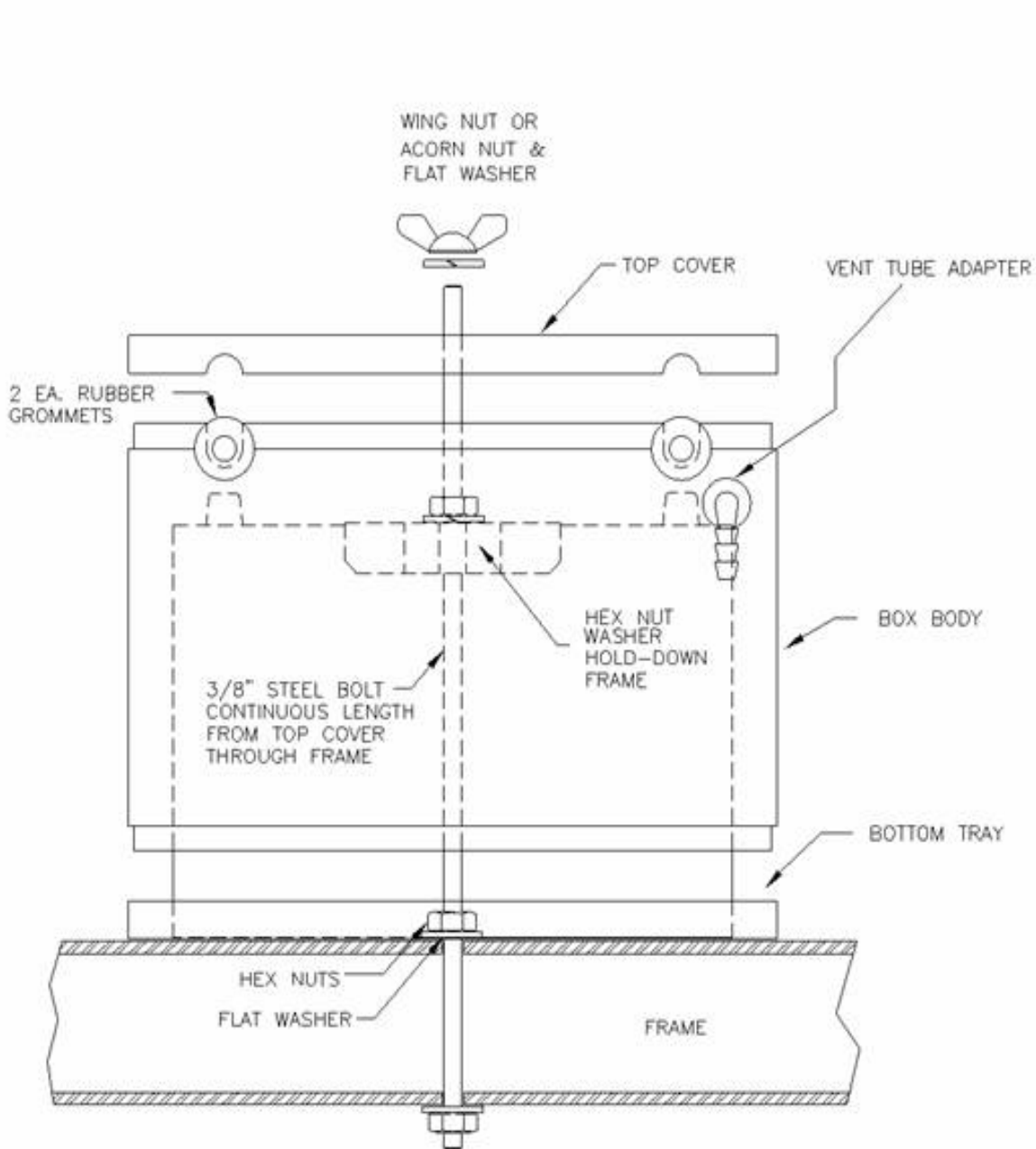

2 EACH 3/8" STEEL THREADED ROD TO PASS THROUGH BATTERY BOX AND SECURE TO VEHICLE'S FRAME

048100 SERIES

8.375